

LOW PRESSURE REDUCER LPR®F

food conformity design
angle design DN 40/50

Application

The self contained low pressure reducing regulators and back pressure regulators controls pressure in mbar range. Applications are for inert gas tank blanketing, reactors, centrifuges and agitating tubs with inert gas such as nitrogen. The regulators are designed to meet requirements in the food, chemical, pharmaceutical and biotechnology industries and are particularly corrosion resistant and reliable.

Design

The large proportioned, spring-loaded diaphragm actuator with directly-controlled valve seat ensures precise control with low hysteresis. The regulators function without auxiliary power supply. High overpressure strength and safe regulator function is achieved by means of the supported diaphragm with long spindle guide. The regulator has a low degree of clearance volume and is self-draining.

Description

The components coming in contact with the product are manufactured from CrNiMo steel 1.4435 / 1.4404. The diaphragm and seals are made of PTFE and the regulator seat is made of perfluoroelastomer (FFKM – Isolast®, Chemraz®, Kalrez®) as standard or FDA compliant perfluoroelastomer. These materials guarantee high corrosion resistance and excellent sealing, even at zero flow. The design has a low degree of clearance volume and is self-draining (suitable for CIP). The surface finish for the stainless-steel version is better than Ra 0.8 for housing parts in contact with the medium, better than Ra 0.8 for internal functional parts and better than Ra 3.2 for the outer housing. Internal welding seams are ground and electro-polished.

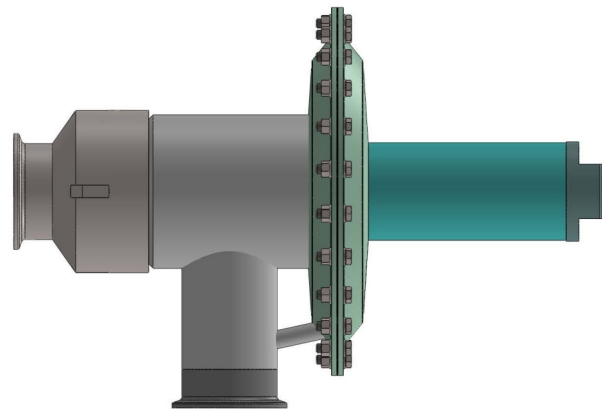
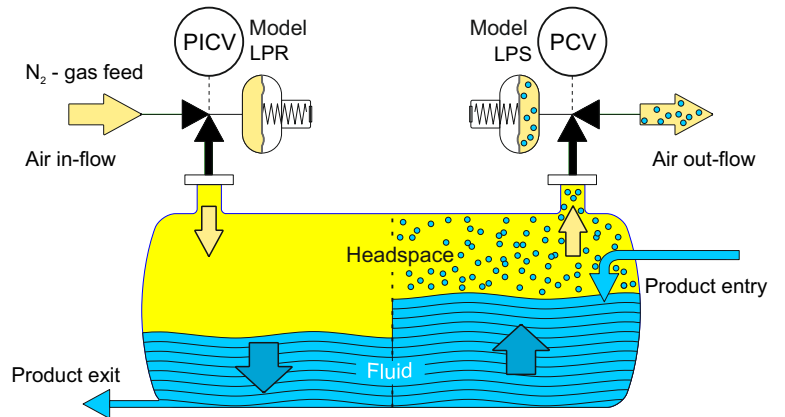

Technical data

Nominal diameter:	DN 40/50 or 1 1/2" / 2"
Regulating range P2:	L.. to 500 mbar D (pressure difference) to 4 bar = P3
Inlet pressure P1:	max. 10 bar
Vakuum proof	
Pressure connections:	Tri-Clamp ISO Schd.5 Special food connection (Special version available on request)
Weight:	6,0 kg to 8,3 kg
Temperature:	-20 ° to +120 °C for EPDM -20 ° to +160 °C for PTFE (Dependent on pressure conditions)
Testing and inspection:	According to IEC 60534-4
Pressure tightness:	Bubble tight sealing category VI

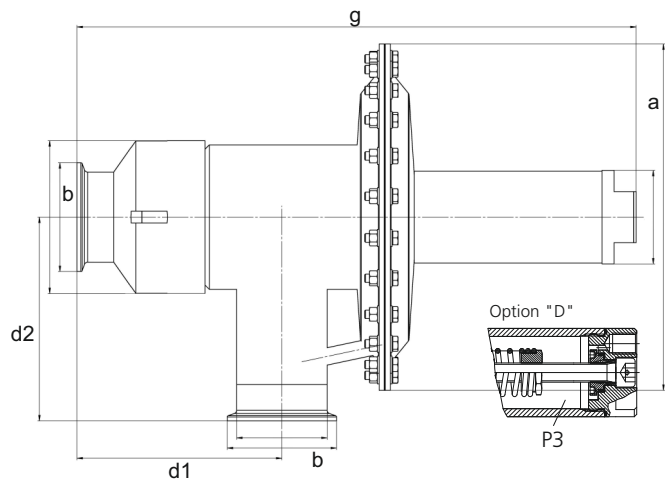

Model dimensions	pressure connection	a	b	g	d1 x d2	e	f Option "D"	c1 Fixed setting P2
LPRF-050...-L...-...	Tri-Clamp ISO Schd.5 SMS	Ø 204	Ø64,0	328	Standard 120 x 120	Ø38 (M36)	G 1/4" female thread (dimen- sion "e" is always Ø54 (M48) with Option "D")	n.d.

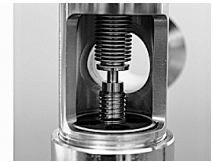
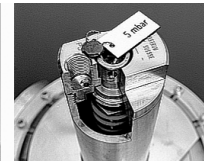
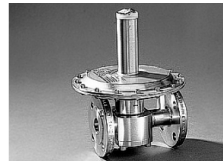

MODEL CODE LPR®

food conformity design
angle design DN 40/50

1				2			3		4			5		6		7
Design				Nominal diameter DN/ pressure connection			Flow capacity		Regulating pressure range			Material		Options		Specials
LP	R	F	-	025	.	-	..	-	...	-	...	-	.	-	Xn	

2 Nominal diameter DN/ Pressure connection

040	DN40 / 1 1/2"
050	DN50 / 2"
T	Tri-Clamp ISO Schd. 5
S	SMS

3 Flow capacity

18	Seat	ø18 mm	kv = 4,1
26	Seat	ø26 mm	kv = 12

Flow table [flow quantities in Nm³/h]

P1 [bar rel.]	0.15	0.25	0.40	0.65	1.0	1.5	2	3	6	10	Seat size
10	41	52	67	84	107	141	163	271	396	596	18
	121	153	196	247	312	414	477	794	1160	1750	26
100	25	40	56	75	97	141	163	271	396	596	18
	74	116	165	219	282	414	477	794	1160	1750	26
200	-	22	44	64	88	141	163	271	396	596	18
	-	64	129	189	257	414	477	794	1160	1750	26

The flow capacity is the same in the super-critical operating range (guide value: $P_2 < 0.5 \times P_1$).
It is recommended to design for operation at a maximum of 70% of the flow values.
P1 = supply pressure P2 = regulating pressure

4 Regulating pressure range P2 (mbar)

L01	2 - 10	L10	16 - 100
L02	4 - 20	L20	30 - 200
L05	8 - 50	L50	80 - 500

Dependency on inlet pressure (per -1 bar / +1 bar change in P1)

Seat ø18 mm	+15 mbar / - 15 mbar
Seat ø26 mm	+ 23 mbar / - 23 mbar

5 Material (only the same colours can be combined)

Housing/ internal components	Seat seal	Diaphragm
S 1.4435 (1.4404)/ 1.4435 (1.4404)	C FFKM con- forms to FDA	P PTFE
	E EPDM	E EPDM
		G PTFE-glass fibre reinforced

Pressure / flow characteristic

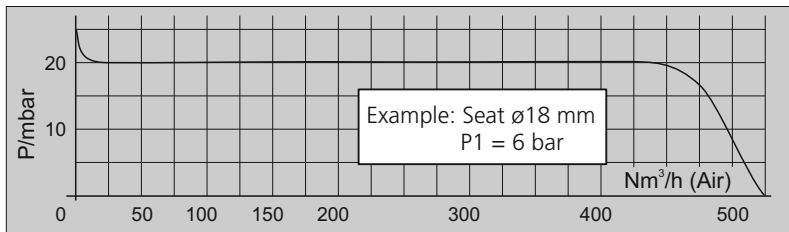

The housing/internal components/spring housing, seat and diaphragms can be combined in any order.

Special materials available on request.

Installation

The preferred installation position is with vertical diaphragm housing and horizontal input. Pressure fixed unit is adjusted in this position. The output pressure increases by approximately 4 mbar for installation with horizontal diaphragm housing. The installation position must be specified.

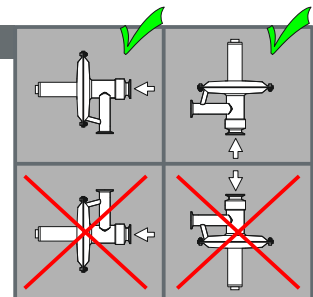

6 Options

D	Differential pressure connection
E*	External impulse connection (standard 5/8"-20 UNS)
G	Pressure gauge connection G 1/4

*The welded nipple is provided for connecting a pipe with ø 10. Included are a Swagelok nut and a front and rear clamping ring. (Specials on request).

7 Specials

X0	If you require, for example, ATEX, PED, special connections, CIP connections on the housing,
X1	welding seams ground on the outside, a fixed setting for P2 ..., please enter an X in this field with the number of desired Specials. Each of the specials must be described in writing.
X2	
•	
•	
Xn	For special versions and certifications, please contact the manufacturer or the appropriate sales representative.

Mounting and start up

- Before connecting the pressure regulator please make sure
 - 1.1 to compare the plant data with the name plate
 - 1.2 the values marked on the name plate are the values measured during our functional inspection
 - 1.3 to check the corrosion resistance of the material
 - 1.4 to blow out impurities in the pipes
 - 1.5 to note the flow direction – it is marked with an arrow on the housing
 - 1.6 to open inlet pipes slowly.
- LPRF adjust reduced pressure: (Relative pressure)
 - 2.1 set a light flow (2Nm³/h). Set the pressure +/- as required using a hexagonal wrench
 - 2.2 the setting can be secured with a seal.
- Adjust the LPRF differential pressure (-D) with the servo-regulator
 - 3.1 if the D-connection is pressurised with the servo-pressure, the working pressure is added by the servo-pressure.